

CEILING SYSTEMS
OPEN GRID

320 series

OPEN CELL LAY-ON

An open cell ceiling system, manufactured of roll formed Aluminum U profile 24mm/15mm wide, made of upper & lower blades to form a 600x600mm modular panels. Fixed on (24mm or 15mm) T-Grid suspension system, in order to allow easy access to ceiling void. Offered in a versatile range of patterns. Special boxes can be provided for MEP Services.

FEATURES

MATERIAL

Aluminum Alloy as per EN AW 3000 or 5000 series.

THICKNESS

0.45mm to 0.7mm.

+ Custom thickness are available upon request

SURFACE FINISH

Plain
Perforated

COATING

Polyester Coating: ((5 μ (Back) + 20 μ (Face))

Polyester Powder Coating: (70 μ -80 μ)

+ High Performance Coatings like PESDF, PVDF and POLYAMIDE are available upon request.

INSULATION

Acoustic Black Fleece is non-flammable and meets the standard DIN 4102 / B1. Classification A1 according to EN 13501-1.

Rockwool slabs conforming to ASTM C612 and equivalent BS 3958-5 are provided for acoustic insulation.

COLORS

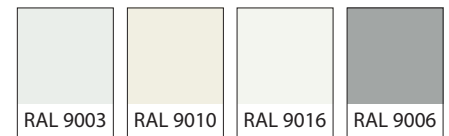

SPECIAL FINISHES



+ See www.rammatal.com for additional colors & special finishes available

SIZES (mm)

	Cell size	Blade width	Blade height
RAM 321	75/100/120/150/200/300	24	33/50
RAM 322	75/100/120/150/200/300	15	37
RAM 323	100 (65 x 35)	0.70	50

+ Custom Sizes available upon request

PERFORATION PATTERNS

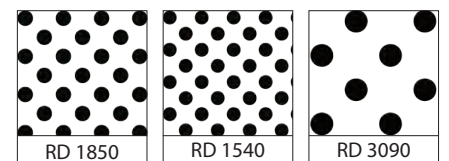

+ See www.rammatal.com for all available pattern options

DATA / PERFORMANCE



ANTI BACTERIAL COATING
Tested as per JIS Z 2801: 2000, which inhibits the growth of bacteria on the applied surface.



LIGHT REFLECTANCE (LR)
Achieved by the metal ceiling is LR – 0.85-0.96 tested as per ASTM E 1477.



FIRE PERFORMANCE
Surface Spread of flame Class 1 tested as per BS 476: Part 7: 1997
“Non-Combustible” Material tested as per BS 476: Part4: 1970
Flame Spread and Smoke Development Index tested as per ASTM E84 (Class 1 or A)

RAM 321 SQUARE/RECTANGULAR (24MM WIDTH) RAM 322 SQUARE/RECTANGULAR (15MM WIDTH) RAM 323 CUBE

ISOMETRIC DETAIL

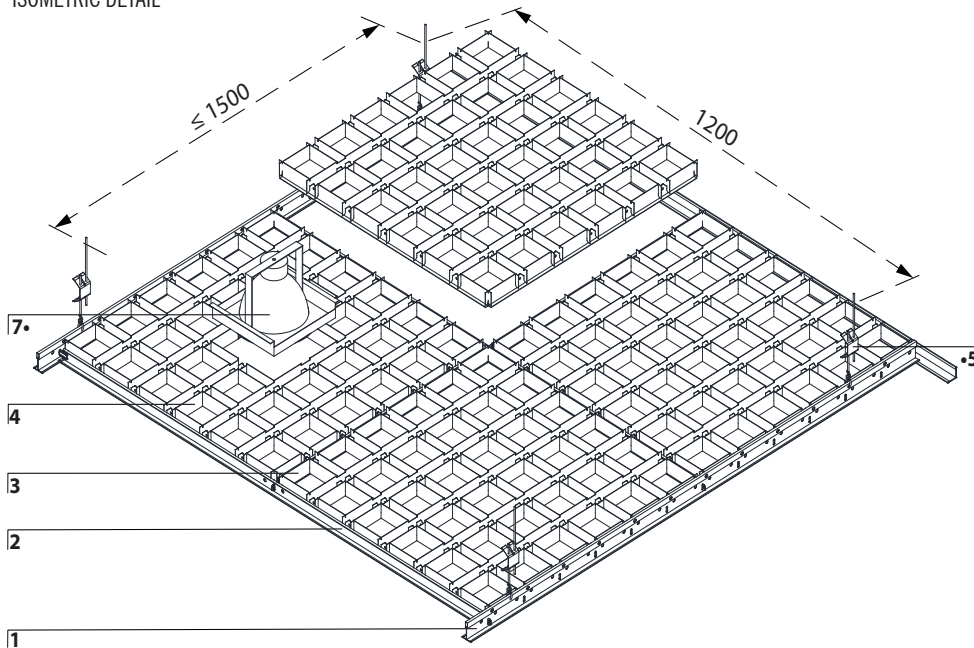

COMPONENTS

- 1 RAM 321/322/323 Main Carrier
- 2 Primary Cross Tee 1200
- 3 Secondary Cross Tee 600
- 4 RAM 321/322/323 Lower & Upper Blade
- 5 Adjustment Clip •
- 6 Wall Trim
- 7 Light Box •
- 8 Threaded Rod •
- 9 Direct Hanging Bracket •
- 10 Anti-Vibration Clip (TR) •

• Optional
Custom sizes can be offered

OPTIONAL HANGING SOLUTIONS

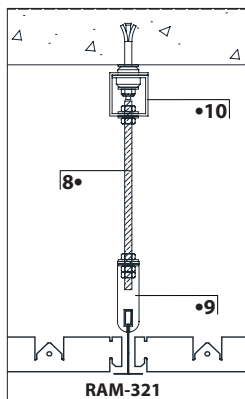

JOINT DETAIL

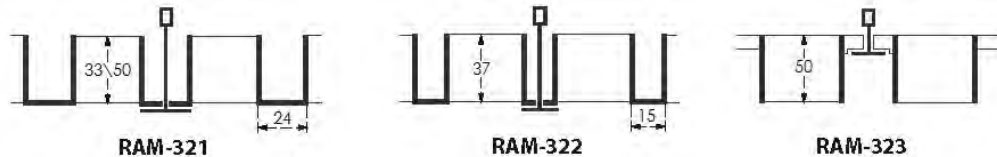

PERIMETER OPTIONS

