

CEILING SYSTEMS
CORRIDOR SOLUTIONS

410 series

SELF SUPPORTED
HOOK-ON



A hook-on type self-supported ceiling for corridor solutions. Modular ceiling panels are laid on concealed 'J' profile. Can be removed from the ceiling and easily restored. Stays hinged to one side of the corridor for damage protection. Easy accessibility to ceiling void without any intermediate support. Offered in a wide range of sizes, colors & finishes.

FEATURES

MATERIAL

Aluminum Alloy as per EN AW 3000 or 5000 series.

Zinc Plated Galvanized Steel G90 grade.

THICKNESS

Aluminum or Galvanized Steel:
0.5mm to 1.0mm.

+ Custom thickness are available upon request

SURFACE FINISH

Plain
Perforated
Decorative Patterns

SIZE (mm)

WIDTH
300 to 700

LENGTH
900 to 3000

EDGE
Square

+ Custom sizes are available upon request

COATING

Polyester Coating: ((5 μ (Back) + 20 μ (Face))

Polyester Powder Coating: (70 μ -80 μ)

+ High Performance Coatings like PESDF, PVDF and POLYAMIDE are available upon request.

INSULATION

Acoustic Black Fleece is non-flammable and meets the standard DIN 4102 / B1. Classification A1 according to EN 13501-1.

Rockwool slabs conforming to ASTM C612 and equivalent BS 3958-5 are provided for acoustic insulation.

COLORS

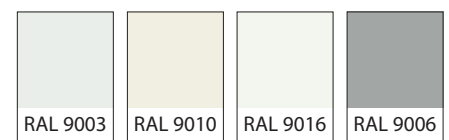

SPECIAL FINISHES

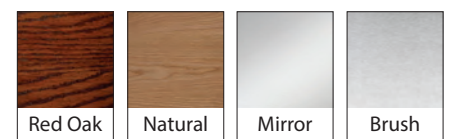

+ See www.rammatal.com for additional colors & special finishes available

+ Special finishes can be provided in lamination, sublimation or coil coating process.

PERFORATION PATTERNS

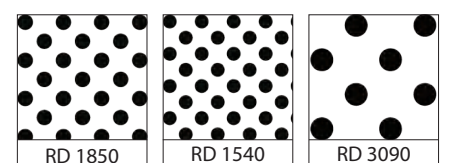

+ See www.rammatal.com for all available pattern options

DATA / PERFORMANCE



ACOUSTICS

Tested as per BS EN ISO 354: 2003 for sound absorption, noise reduction and sound attenuation.

NRC achieved with Acoustic Black fleece – NRC 0.75

NRC achieved with Acoustic Black Fleece and Rockwool Insulation – NRC 1.00

Tested as per ASTM E1414-11a for Airborne Sound Attenuation as per ISO 10848-2.

CAC can achieved up to – 48 dB

Perforated & Sound Attenuation cover



ANTI BACTERIAL COATING

Tested as per JIS Z 2801: 2000, which inhibits the growth of bacteria on the applied surface.



LIGHT REFLECTANCE (LR)

Achieved by the metal ceiling is LR – 0.85-0.96 tested as per ASTM E 1477.



FIRE PERFORMANCE

Surface Spread of flame Class 1 tested as per BS 476: Part 7: 1997

“Non-Combustible” Material tested as per BS 476: Part4: 1970

Flame Spread and Smoke Development Index tested as per ASTM E84 (Class 1 or A)

RAM 411 HOOK-ON

ISOMETRIC DETAIL

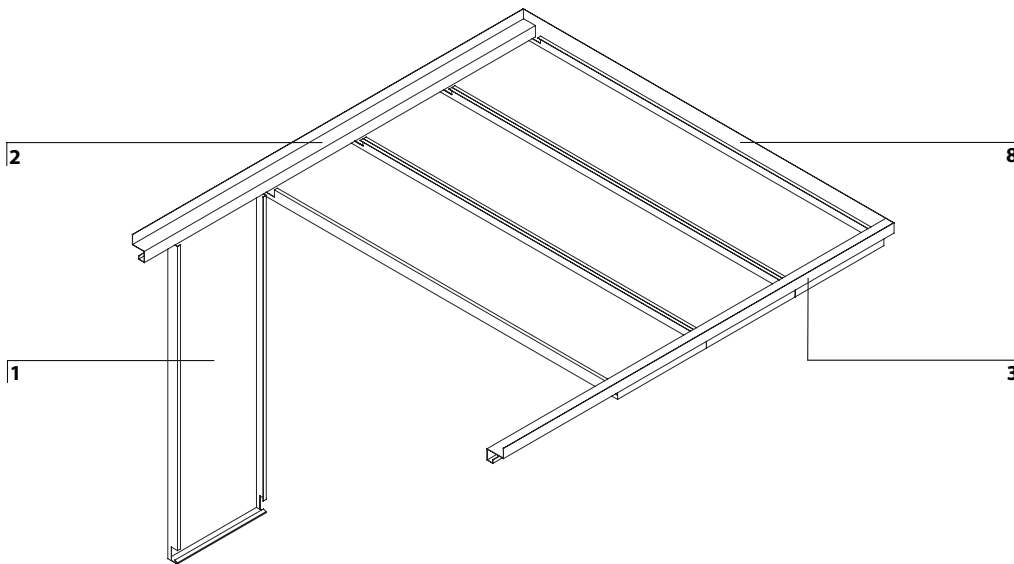

COMPONENTS

- 1 Panel
- 2 JU Profile (Fix)
- 3 JV Profile (Fix)
- 4 Z Profile Support Bracket
- 5 Bolt & Nut
- 6 JU Profile (Adjustable)
- 7 JV Profile (Adjustable)
- 8 Shadow Cover Profile
- 9 U Channel Profile



Luminous Panel •

• Optional

Custom sizes can be offered

CARRIER DETAILS

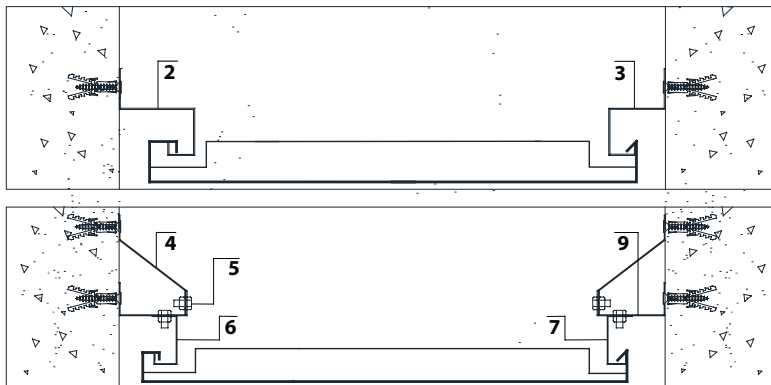

PERIMETER OPTIONS

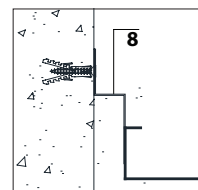

PANEL JOINTS DETAIL

